

BRAKE BOOSTER PUSH ROD ADJUSTMENT TOOL

The master cylinder push rod length gauge is designed to measure the depth of the master cylinder piston bore in order to adjust the length of the booster push rod pin, enabling precise and safe operation.

The two ends of the booster push rod pin adjustment tool are designed with a magnetic inner core.

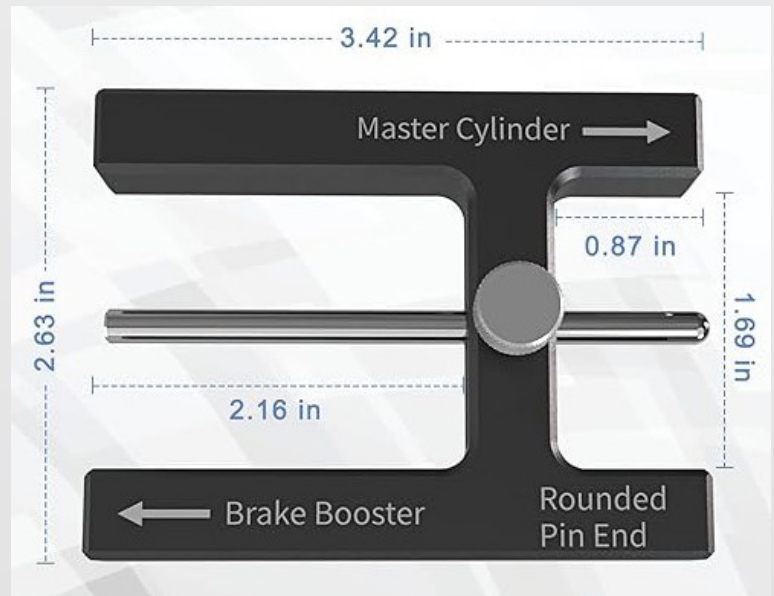

The tool enables the Brake Booster Pushrod clearance to be set accurately.

- a) Too much clearance results in longer pedal travel.
- b) Too little clearance results PRELOAD and brake pad drag .

ADJUSTMENT/CLEARANCE IS REQUIRED AT THIS POINT.

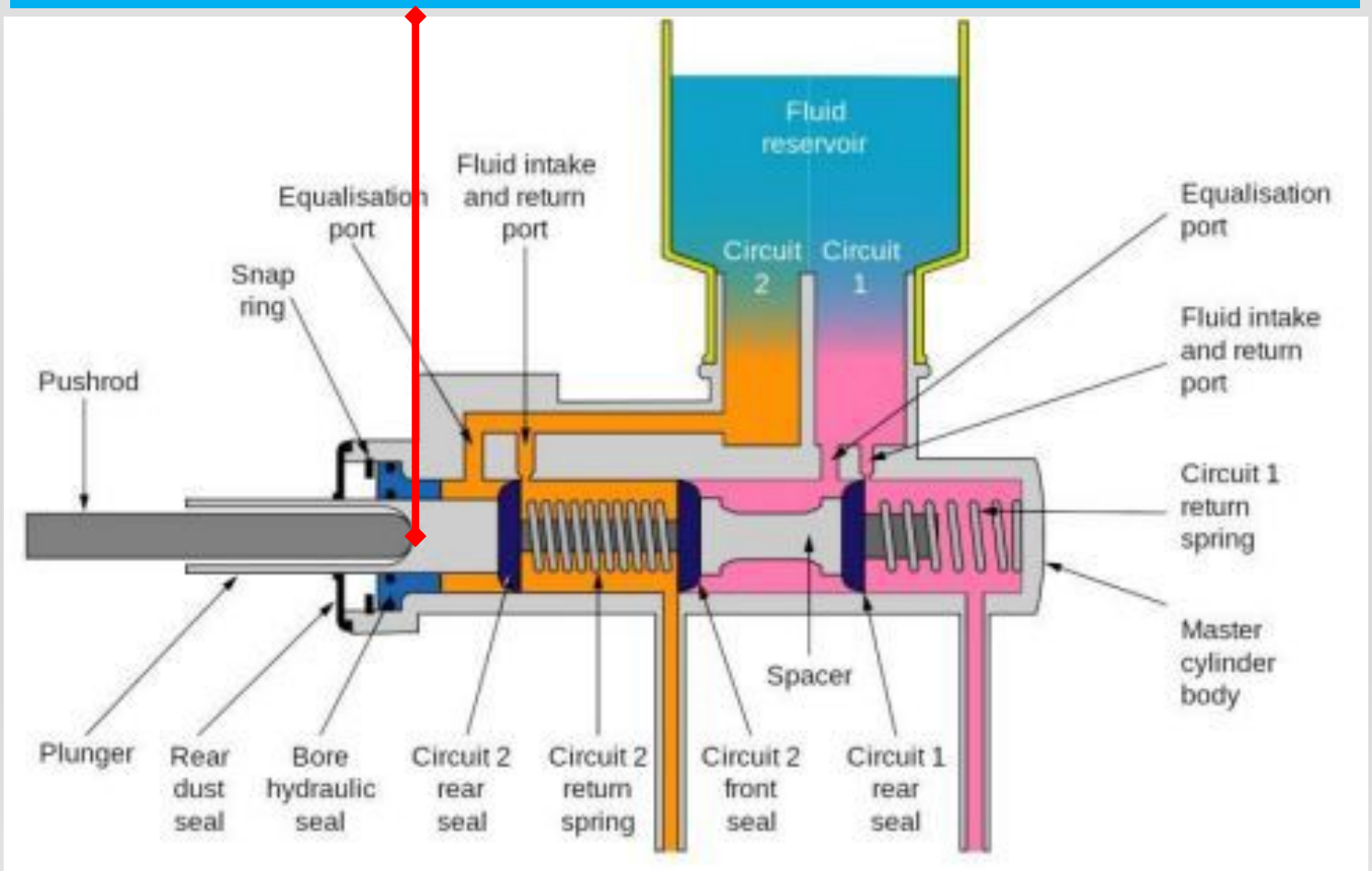

Ideal Gap Distance from Pin to Master Cylinder

Master Power Brakes recommends that the distance between the pin from the booster and the hole in your master cylinder be **approximately 0.020" - 0.5mm**.

If this distance is **greater than 0.020"**, this will cause a soft brake pedal and excess pedal travel.

If the distance is **less than 0.020"**, the master cylinder may not return fully and cause brake drag.

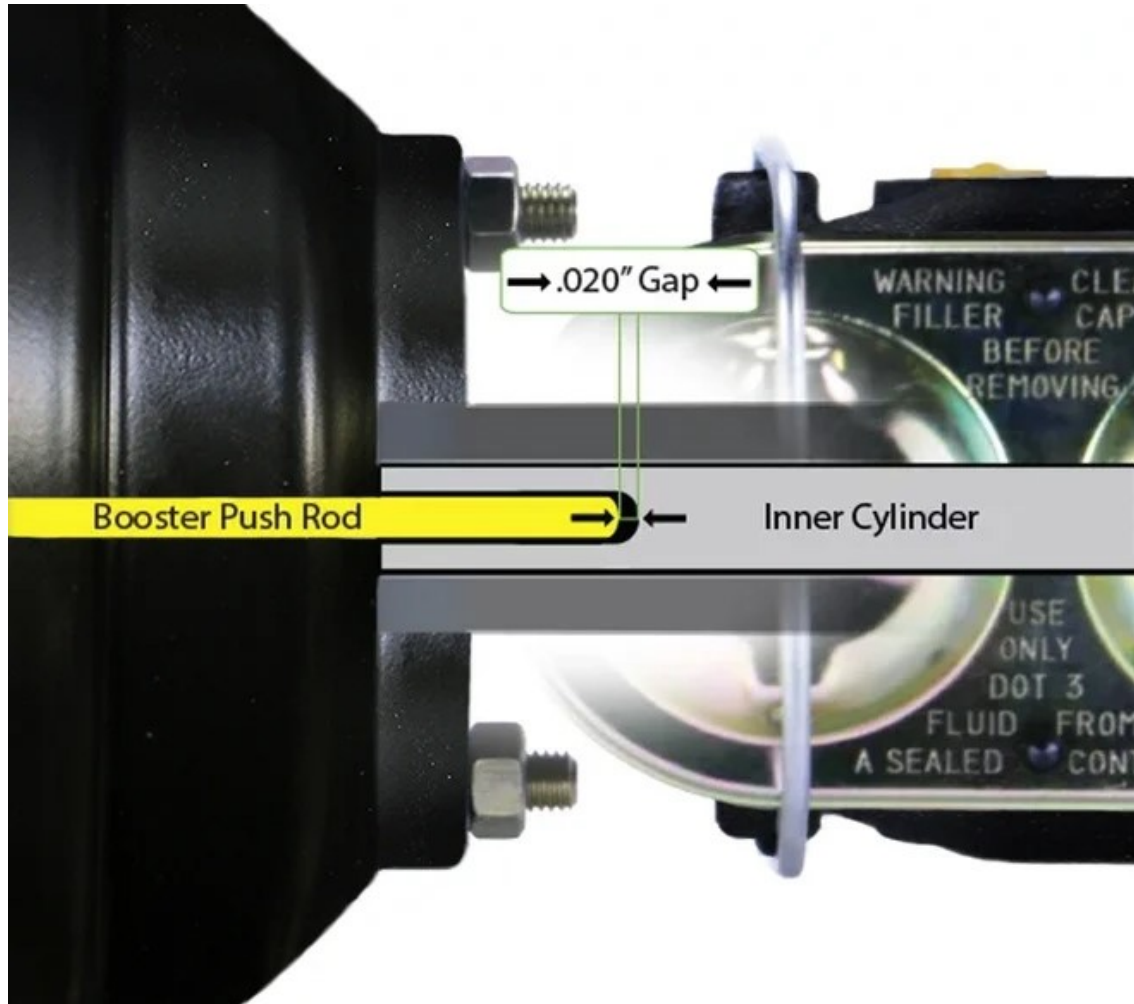

CUT OUT ILLUSTRATION:

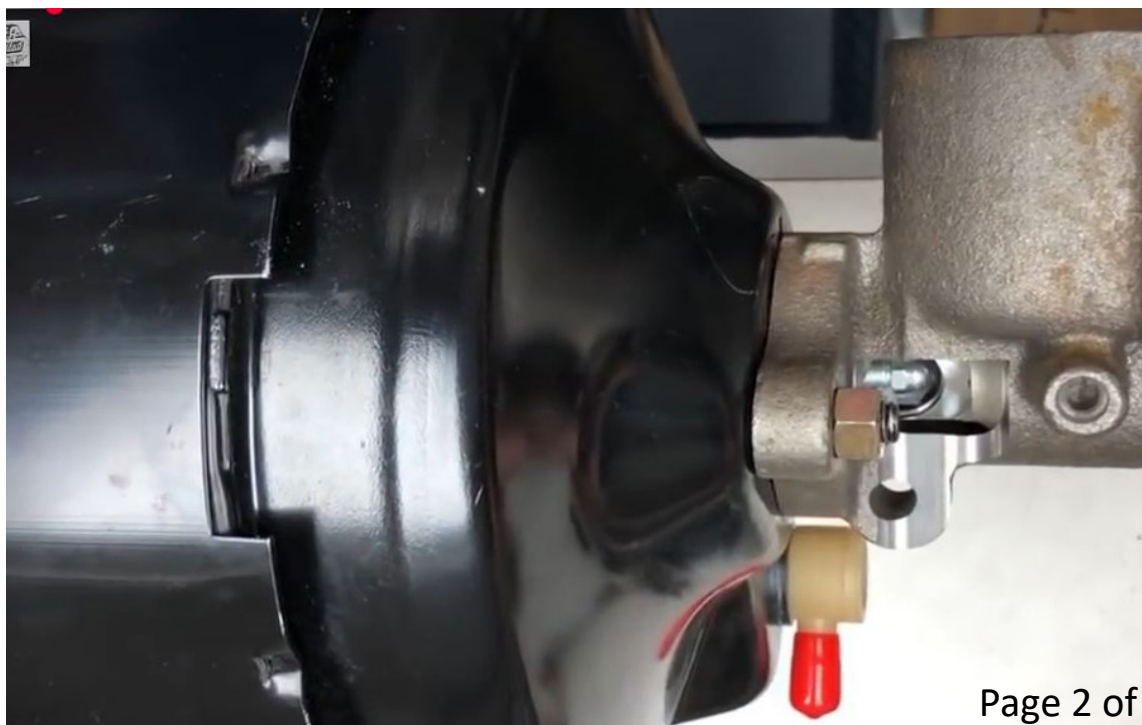

How to use



Attach the "Master Cylinder" end of the brake booster adjustment tool to the surface of the master cylinder as shown.



Adjust the round knob to measure the depth of the piston hole. When measuring, let the pin touch the middle of the bottom of the piston hole without pushing the piston, then lock the round knob.



Attach the "Brake Booster" end of the brake booster adjustment tool to the surface of the brake booster as shown, adjust the length of the push rod until there is about a little bit of an air gap there between the pin and the push rod.



Finally, connect the master cylinder and the brake booster to complete the adjustment and installation process.



Go to the following link for an excellent YouTube video on use of the tool and setup of the Pushrod clearance.

https://www.youtube.com/watch?v=Wl_CXBJ6J3E

AUMOTORSPORT

BRAKE, CLUTCH & PARTS WAREHOUSE

02 4388 0354

Illustrative Jpegs



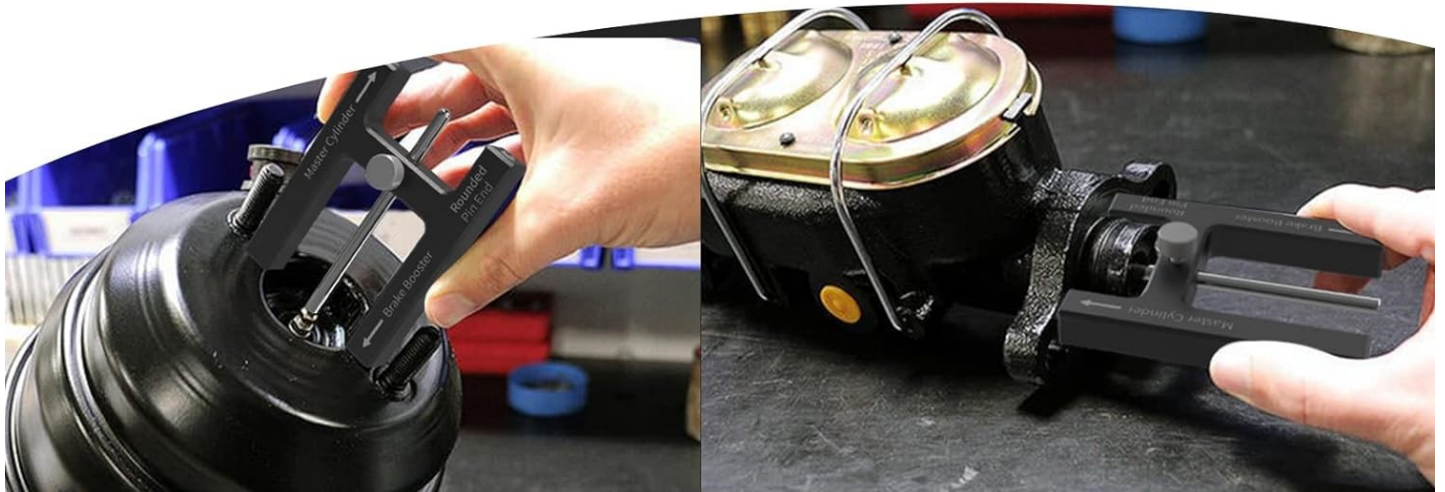
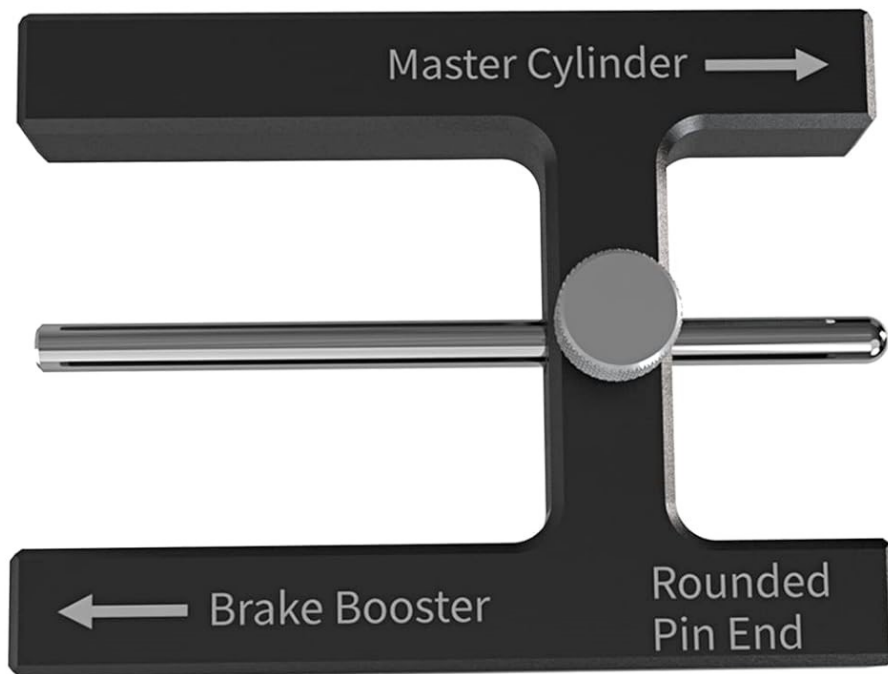

PUSHROD SPACER:

If required, it should be supplied with Master Cylinder.

